

STATE OF UTAH



OFFICE OF THE LIEUTENANT GOVERNOR

CERTIFICATE OF ANNEXATION

I, Deidre M. Henderson, Lieutenant Governor of the State of Utah, hereby certify that there has been filed in my office a notice of annexation known as the RED BRIDGE PUBLIC INFRASTRUCTURE DISTRICT NO. 2 PLAT C, PLAT D, PLAT E ANNEXATION, located in PAYSON CITY, dated JANUARY 6, 2023, complying with Section §17B-1-414 Utah Code Annotated, 1953, as amended.

Now, therefore, notice is hereby given to all whom it may concern that the attached is a true and correct copy of the notice of annexation, referred to above, on file with the Office of the Lieutenant Governor pertaining to the RED BRIDGE PUBLIC INFRASTRUCTURE DISTRICT NO. 2 PLAT C, PLAT D, PLAT E ANNEXATION, located in UTAH COUNTY, State of Utah.

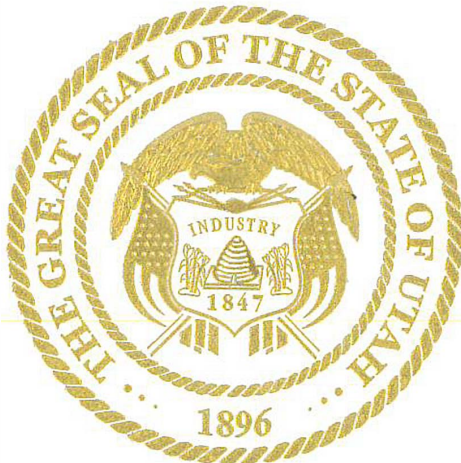

IN TESTIMONY WHEREOF, I have hereunto set my hand, and affixed the Great Seal of the State of Utah this 6th day of January, 2023 at Salt Lake City, Utah.

A handwritten signature in black ink that reads "Deidre M. Henderson".

DEIDRE M. HENDERSON
Lieutenant Governor

NOTICE OF IMPENDING BOUNDARY ACTION

TO: The Lieutenant Governor, State of Utah

NOTICE IS HEREBY GIVEN that the Board of Directors of Red Bridge Public Infrastructure District No. 2, Utah, acting in its capacity on 22 December 2022, adopted Resolution- Annexation of Properties Into District, a true and correct copy of which is attached hereto and incorporated by this reference herein (the "Annexation Resolution").

WHEREAS the property owners of the properties listed in Exhibit A have petitioned the board to be annexed into the Red Bridge Public Infrastructure District No. 2.

WHEREAS the Board Red Bridge Public Infrastructure District No. 2, hereby certifies that, pursuant to Utah Code Ann. § 17B-1 and § 17B-2a, all legal requirements applicable to the Annexation Resolution, have been met.

THEREFORE, the Board of Directors of Red Bridge Public Infrastructure District No. 2, hereby respectfully requests the annexation of the properties herein identified to be known as the RBPID2 December 2022 Annexation on the Annexation Certificate, pursuant to and in conformance with the provisions of Utah Code Ann. § 17B-1 and § 17B-2a

DATED this 29th day of December 2022.

BOARD OF DIRECTORS,

RED BRIDGE PUBLIC INFRASTRUCTURE DISTRICT NO. 2

Joseph A Spencer

SignNow e-signature ID: 9dbbeae10e...

12/29/2022 16:26:41 UTC
Joseph A. Spencer, Chair

ATTEST:

SHEILA MICHAELIS

By: *Sheila Michaelis*

SignNow e-signature ID: cbd1d85cbd...

12/29/2022 16:24:56 UTC
District Clerk

Document History

SignNow E-Signature Audit Log

All dates expressed in MM/DD/YYYY (US)

Document name: LT Gov NOTICE OF IMPENDING BOUNDARY ACTION PID 2
Document created: 12/29/2022 16:19:06
Document pages: 1
Document ID: 86559e64e5074b0291f3b862f641967f9de6d850
Document Sent: 12/29/2022 16:20:34 UTC
Document Status: Signed
 12/29/2022 16:20:41UTC

Sender: josephspencer@gmail.com
Signers: josephspencer@gmail.com, paysonsouthmeadowspartners@gmail.com
CC:

Client	Event	By	Server Time	Client Time	IP Address
SignNow Web Application	Uploaded the Document	josephspencer@gmail.com	12/29/2022 16:19:06 pm UTC	12/29/2022 16:19:05 pm UTC	73.127.23.18
SignNow Web Application	Viewed the Document	josephspencer@gmail.com	12/29/2022 16:20:03 pm UTC	12/29/2022 16:20:04 pm UTC	73.127.23.18
SignNow Web Application	Document Saved	josephspencer@gmail.com	12/29/2022 16:20:29 pm UTC	12/29/2022 16:20:30 pm UTC	73.127.23.18
SignNow Web Application	Invite Sent to: josephspencer@gmail.com	josephspencer@gmail.com	12/29/2022 16:20:34 pm UTC	12/29/2022 16:20:35 pm UTC	73.127.23.18
SignNow Web Application	Viewed the Document	josephspencer@gmail.com	12/29/2022 16:20:36 pm UTC	12/29/2022 16:20:36 pm UTC	73.127.23.18
SignNow Web Application	Invite Sent to: paysonsouthmeadowspartners@gmail.com	josephspencer@gmail.com	12/29/2022 16:20:41 pm UTC		73.127.23.18
SignNow Web Application	Signed the Document, Signature ID: 9bdbbae10ea143ecb783	josephspencer@gmail.com	12/29/2022 16:20:41 pm UTC	12/29/2022 16:20:42 pm UTC	73.127.23.18
SignNow Web Application	Document Saved	josephspencer@gmail.com	12/29/2022 16:20:41 pm UTC	12/29/2022 16:20:42 pm UTC	73.127.23.18
SignNow Web Application	Viewed the Document	paysonsouthmeadowspartners@gmail.com	12/29/2022 16:24:47 pm UTC	12/29/2022 16:24:47 pm UTC	107.77.227.109
SignNow Web Application	Signed the Document, Signature ID: cbd1d85cbd9b4eb39e19	paysonsouthmeadowspartners@gmail.com	12/29/2022 16:24:56 pm UTC	12/29/2022 16:24:56 pm UTC	107.77.227.109
SignNow Web Application	Document Saved	paysonsouthmeadowspartners@gmail.com	12/29/2022 16:24:56 pm UTC	12/29/2022 16:24:56 pm UTC	107.77.227.109

WHEN RECORDED PLEASE RETURN TO:

Sheila Michaelis
84 North 500 East
Salem, Utah 84653

**NOTICE OF ANNEXATION OF PROPERTY INTO
RED BRIDGE PUBLIC INFRASTRUCTURE DISTRICT NO. 2**

Notice is hereby given that Red Bridge Public Infrastructure District No. 2 (the "District") has annexed the property described in *Exhibit A* hereto into the District (the "Annexed Property"). The boundaries of the District, including the Annexed Property, are described in *Exhibit B* hereto. The District may finance and repay infrastructure and other improvements through the levy of a property tax on property located in the District, including the Annexed Property. The maximum mill levy of the District to repay such financing ("*Limited Tax Bonds*") is 10 mills. Without any further election or consent of property owners or registered voters, including property owners or registered voters of the Annexed Property, the District may convert any Limited Tax Bonds to a general obligation bond if the principal amount of the Limited Tax Bonds together with the principal amount of other related outstanding general obligation bonds of the District does not exceed 15% of the fair market value of taxable property in the District.

RED BRIDGE PUBLIC INFRASTRUCTURE DISTRICT
NO. 2

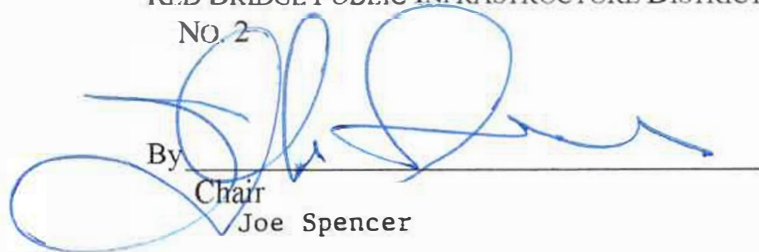
By  _____
Chair
Joe Spencer

STATE OF UTAH)
 : SS.
COUNTY OF UTAH)

On the 27th day of December, 2022, Joe Spencer personally appeared before me and did say that he is the Chair of the Board of Trustees of Red Bridge Public Infrastructure District No. 2, which executed the foregoing instrument.

IN WITNESS WHEREOF, I have hereunto set my hand and official seal on the day and year in this certificate first above written.



Cheyenne K Sullivan
NOTARY PUBLIC
Residing at: Provo, UT, Utah

EXHIBIT A

DESCRIPTION OF PROPERTY

PARCEL 1

Tax Parcel: 30-060-0131
COM N 1801.38 FT & E 1319.9 FT FR SW COR. SEC. 18, T9S, R2E, SLB&M.;
S 183.35 FT; S 76 DEG 6' 55" W 205.4 FT; N 13 DEG 52' 8" W 246.01 FT; S 88
DEG 37' 30" E 258.44 FT TO BEG.

PARCEL 2:

Tax Parcel: 30-060-0046
COM N 89 DEG 42' 17" E 1356.63 FT & N 1818.55 FT FR SW COR. SEC. 25
T9S R2E SLB&M.; N 88 DEG 45' 0" W 54.44 FT; N 1 DEG 23' 39" W 56.6 FT; N
76 DEG 7' 52" E 40.33 FT; S 13 DEG 52' 8" E 69.46 FT TO BEG.

PARCEL 3:

Tax Parcel: 30-060-0126
COM N 859.73 FT & E 1295.56 FT & N 13 DEG 52' 8" W 289.41 FT FR SW
COR. SEC. 18, T9S, R2E, SLB&M.; N 13 DEG 52' 8" W 314.9 FT; N 76 DEG 6'
55" E 174.29 FT; S 368.85 FT; N 77 DEG 11' 14" W 96.11 FT TO BEG.

PARCEL 4:

Tax Parcel: 30-060-0129
COM N 1801.14 FT & E 1339.96 FT FR SW COR. SEC. 18, T9S, R2E, SLB&M.;
S 88 DEG 37' 30" E 22.82 FT; S 13 DEG 52' 8" E 140.84 FT; ALONG A CURVE
TO R (CHORD BEARS: S 10 DEG 24' 13" W 28.63 FT, RADIUS = 35 FT); S 76
DEG 6' 55" W 52.95 FT; N 178.15 FT TO BEG.

PARCEL 5:

Tax Parcel: 30-060-0130
COM N 89 DEG 42' 6" E 1349.9 FT & N 1609.35 FT & N 0 DEG 28' 25" W
184.56 FT & S 88 DEG 37' 30" E 14.34 FT FR SW COR. SEC. 18, T9S, R2E,
SLB&M.; N 13 DEG 52' 19" W 25.78 FT; N 88 DEG 45' 45" W 333.59 FT; S 75
DEG 0' 0" W 86.22 FT; S 88 DEG 37' 30" E 380.29 FT; S 183.35 FT; N 76 DEG 6'
55" E 20.67 FT; N 178.15 FT; S 88 DEG 37' 30" E 22.74 FT TO BEG.

PARCEL 6:

Tax Parcel: 30-060-0127
COM N 89 DEG 42' 6" E 1319.92 FT & N 1112.52 FT FR SW COR. SEC. 18,
T9S, R2E, SLB&M.; N 368.85 FT; N 76 DEG 6' 55" E 20.66 FT; S 378.37 FT; N
77 DEG 11' 14" W 20.57 FT TO BEG.

PARCEL 7:

Tax Parcel: 30-060-0132
COM N 89 DEG 42' 17" E 998.6 FT & N 1533.46 FT FR SW COR. SEC. 18, T9S,
R2E. SLB&M.: N 270.45 FT; S 88 DEG 37' 32" E 62.94 FT; S 13 DEG 52' 8" E
245.98 FT; S 76 DEG 6' 55" W 125.55 FT TO BEG.

PARCEL 8:

Tax Parcel: 30-060-0125
COM N 89 DEG 42' 17" E 998.6 FT & N 1187.32 FT FR SW COR. SEC. 18, T9S,
R2E. SLB&M.: N 216.35 FT; N 76 DEG 6' 55" E 156.67 FT; S 13 DEG 52' 8" E
314.88 FT; N 77 DEG 11' 14" W 233.38 FT TO BEG.

PARCEL 9:

Tax Parcel: 30-060-0104
COM N 89 DEG 42' 17" E 998.59 FT & N 854.55 FT FR SW COR. SEC. 18, T9S,
R2E. SLB&M.: N 244.56 FT; S 77 DEG 11' 14" E 257.05 FT; S 13 DEG 52' 8" E
193.19 FT; W 296.96 FT TO BEG.

EXHIBIT B

**DESCRIPTION OF DISTRICT BOUNDARIES INCLUDING
THE ANNEXED PROPERTY**

[Insert plat map]

EXHIBIT B

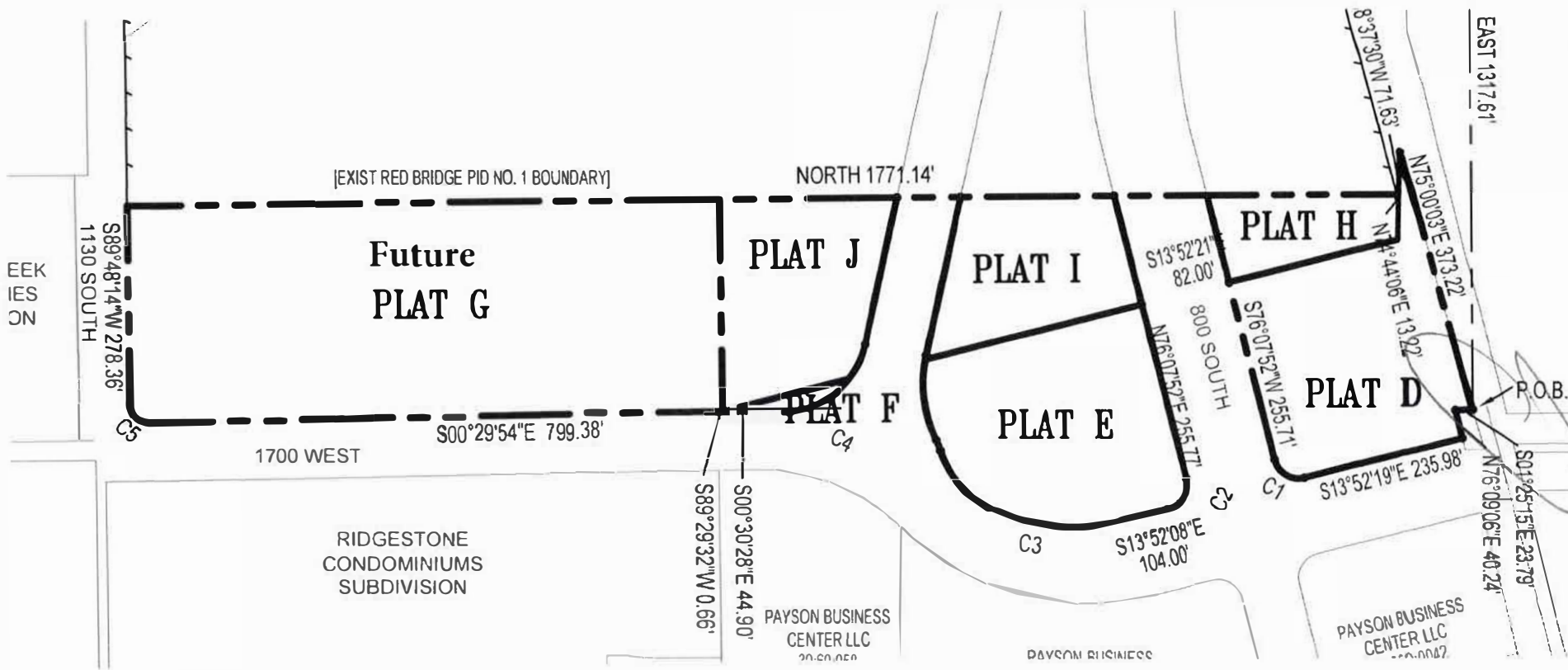

EEK
IES
ON

**Property Owner Consent to
Public Infrastructure District and Bonds**

The undersigned PAYSON SOUTH MEADOW PARTNERS, LLC (the "*Property Owner*"), owner of the property described in *Exhibit A* (the "*Property*"), hereby consents to the following:

- (a) The inclusion of the Property into Red Bridge Public Infrastructure District No. 2 (the "*District*") pursuant to Title 17B of the Utah Code Annotated 1953, as amended (the "*Act*");
- (b) The levy by the District and all other public infrastructure districts within the boundaries of the District, collectively, of a property tax of not to exceed 0.010 per dollar of taxable value of taxable property within the District, and acknowledge that the Property will be subject to such tax;
- (c) The issuance by the District of Limited Tax Bonds (the "*Bonds*") in a principal amount not to exceed \$25,000,000 for the purpose of paying all or a portion of the costs of public infrastructure, as permitted under the Act, and the authorization and issuance of the Bonds due and payable with a term not to exceed 40 years from the date of issuance of the Bonds;
- (d) The District working with Red Bridge Public Infrastructure District No. 2 in issuing the Bonds pursuant to Title 11, Chapter 13 of the Utah Code Annotated 1953, as amended;
- (e) The Bonds being repaid from property taxes assessed against properties within the boundaries of the District, subject to an aggregate public infrastructure district maximum mill levy of .010 per dollar of taxable value of taxable property in the District;

The Property Owner acknowledges that pursuant to Section 17B-2a-1207 of the Act, this consent to the issuance of the Bonds is sufficient to meet any statutory or constitutional election requirement necessary for the issuance of the limited tax bond. The Property Owner further acknowledges that such Bonds may, without further election or consent of property owners or registered voters, be converted by the District to general obligation bonds, in accordance with the provisions of the Act.

The undersigned is the 100% owner of the Property and certifies that there are no registered voters residing within such parcel(s).

PAYSON SOUTH MEADOW PARTNERS, LLC, a
Utah limited liability company

By 
Name: JOSEPH A. SPENCER
Its: Manager

STATE OF UTAH)

ss:

COUNTY OF Utah)

The foregoing instrument was acknowledged before me this 27th day of December,
2022, by Joseph A. Spencer

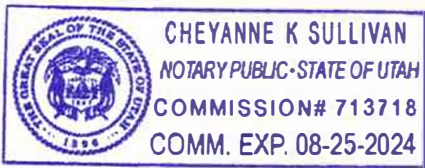

NOTARY PUBLIC

EXHIBIT A

DESCRIPTION OF PROPERTY

PARCEL 1

Tax Parcel: 30-060-0131
COM N 1801.38 FT & E 1319.9 FT FR SW COR. SEC. 18, T9S, R2E, SLB&M.:
S 183.35 FT; S 76 DEG 6' 55" W 205.4 FT; N 13 DEG 52' 8" W 246.01 FT; S 88
DEG 37' 30" E 258.44 FT TO BEG.

PARCEL 2:

Tax Parcel: 30-060-0046
COM N 89 DEG 42' 17" E 1356.63 FT & N 1818.55 FT FR SW COR. SEC. 25
T9S R2E SLB&M.: N 88 DEG 45' 0" W 54.44 FT; N 1 DEG 23' 39" W 56.6 FT; N
76 DEG 7' 52" E 40.33 FT; S 13 DEG 52' 8" E 69.46 FT TO BEG.

PARCEL 3:

Tax Parcel: 30-060-0126
COM N 859.73 FT & E 1295.56 FT & N 13 DEG 52' 8" W 289.41 FT FR SW
COR. SEC. 18, T9S, R2E, SLB&M.: N 13 DEG 52' 8" W 314.9 FT; N 76 DEG 6'
55" E 174.29 FT; S 368.85 FT; N 77 DEG 11' 14" W 96.11 FT TO BEG.

PARCEL 4:

Tax Parcel: 30-060-0129
COM N 1801.14 FT & E 1339.96 FT FR SW COR. SEC. 18, T9S, R2E, SLB&M.:
S 88 DEG 37' 30" E 22.82 FT; S 13 DEG 52' 8" E 140.84 FT; ALONG A CURVE
TO R (CHORD BEARS: S 10 DEG 24' 13" W 28.63 FT, RADIUS = 35 FT); S 76
DEG 6' 55" W 52.95 FT; N 178.15 FT TO BEG.

PARCEL 5:

Tax Parcel: 30-060-0130
COM N 89 DEG 42' 6" E 1349.9 FT & N 1609.35 FT & N 0 DEG 28' 25" W
184.56 FT & S 88 DEG 37' 30" E 14.34 FT FR SW COR. SEC. 18, T9S, R2E,
SLB&M.: N 13 DEG 52' 19" W 25.78 FT; N 88 DEG 45' 45" W 333.59 FT; S 75
DEG 0' 0" W 86.22 FT; S 88 DEG 37' 30" E 380.29 FT; S 183.35 FT; N 76 DEG 6'
55" E 20.67 FT; N 178.15 FT; S 88 DEG 37' 30" E 22.74 FT TO BEG.

PARCEL 6:

Tax Parcel: 30-060-0127
COM N 89 DEG 42' 6" E 1319.92 FT & N 1112.52 FT FR SW COR. SEC. 18,
T9S, R2E, SLB&M.: N 368.85 FT; N 76 DEG 6' 55" E 20.66 FT; S 378.37 FT; N
77 DEG 11' 14" W 20.57 FT TO BEG.

PARCEL 7:

Tax Parcel: 30-060-0132

COM N 89 DEG 42' 17" E 998.6 FT & N 1533.46 FT FR SW COR. SEC. 18, T9S,
R2E, SLB&M.: N 270.45 FT; S 88 DEG 37' 32" E 62.94 FT; S 13 DEG 52' 8" E
245.98 FT; S 76 DEG 6' 55" W 125.55 FT TO BEG.

PARCEL 8:

Tax Parcel: 30-060-0125

COM N 89 DEG 42' 17" E 998.6 FT & N 1187.32 FT FR SW COR. SEC. 18, T9S,
R2E, SLB&M.: N 216.35 FT; N 76 DEG 6' 55" E 156.67 FT; S 13 DEG 52' 8" E
314.88 FT; N 77 DEG 11' 14" W 233.38 FT TO BEG.

PARCEL 9:

Tax Parcel: 30-060-0104

COM N 89 DEG 42' 17" E 998.59 FT & N 854.55 FT FR SW COR. SEC. 18, T9S,
R2E, SLB&M.: N 244.56 FT; S 77 DEG 11' 14" E 257.05 FT; S 13 DEG 52' 8" E
193.19 FT; W 296.96 FT TO BEG.

**PETITION REQUESTING ANNEXATION INTO
RED BRIDGE PUBLIC INFRASTRUCTURE DISTRICT NO. 2**

December 22, 2022

City of Payson, Utah
Attention: City Recorder
495 West Utah Avenue
Payson, Utah 84651

Red Bridge Public Infrastructure
District No. 2
Attention: Chair
754 East 1200 North
Pleasant Grove, Utah 84062

The undersigned PAYSON SOUTH MEADOW PARTNERS, LLC (the "*Petitioner*") hereby requests inclusion of the property described in *Exhibit A* (the "*Property*") into Red Bridge Public Infrastructure District No. 2 (the "*District*") pursuant to the Local District Act, Title 17B, Chapter 1, Utah Code Annotated 1953 and the Public Infrastructure District Act, Title 17B, Chapter 2a, Utah Code Annotated 1953 (collectively, the "*Act*").

Section 1. Request for Annexation into Public Infrastructure District. The Petitioner hereby requests annexation by the District of the Property into the District in order to assist in the financing of public infrastructure relating to the development of the Property, as permitted under the Act, including but not limited to certain facilitates the installation of approximately 14,000 lineal feet of sewer main that will serve the District area (collectively, the "*Improvements*").

Section 2. Petitioner.

- (a) The Petitioner is Payson South Meadow Partners, LLC.
- (b) The designated contact person for the Petitioner is:

Sheila Michaelis
84 North 500 East
Salem, Utah 84653
Phone: (801) 369-2638
E-mail: commercialagent10@gmail.com

Section 3. Petitioner Representations. The undersigned, as Petitioner, hereby represents and warrants that:

- (a) The undersigned is authorized to sign on behalf of the undersigned Petitioner;

- (b) The Property is located within the boundaries of the Annexation Area of the District;
- (c) The Petitioner has taken all action necessary to execute and deliver the Petition;
- (d) The execution and delivery of the Petition by the Petitioner does not materially conflict with, violate or constitute on the part of the Petitioner a breach or violation of any of the terms and provisions of, or constitute a default under (i) an existing constitution, law or administrative rule or regulation, decree, order or judgment; (ii) any corporate restriction or any bond, debenture, note, mortgage, indenture, agreement or other instrument to which the Petitioner is a party or by which the Petitioner is or may be bound or to which any of the property or assets of the Petitioner is or may be subject; or (iii) the creation and governing instruments of the Petitioner, if applicable; and
- (e) To the knowledge of the Petitioner, there is no action, suit, proceeding, inquiry or investigation at law or in equity by or before any court or public board or body and to which the Petitioner is party, or threatened against the Petitioner wherein an unfavorable decision, ruling or finding would materially adversely affect the validity or enforceability or the execution and delivery by the Petitioner of the Petition.
- (f) There are no registered voters residing within the Property.
- (g) The Petitioner is the sole owner of the Property.

Section 4. Petitioner Consent. The Petitioner hereby consents to:

- (a) The inclusion of the Property in the District;
- (b) A waiver of the residency requirement for members of the Board of Trustees of the District as permitted under Section 17B-2a-1205(3)(a) of the Act;
- (c) A waiver of the entirety of the protest period described in Section 17B-1-213 of the Act pursuant to Section 17B-2a-1204(2)(b) of the Act;
- (d) The levy by the District and all other public infrastructure districts within the boundaries of the District, collectively, of a property tax of not to exceed 0.010 per dollar of taxable value of taxable property within the District, and acknowledge that the Property will be subject to such tax;
- (e) The issuance by the District of bonds repayable through property taxes.

Section 5. Electronic Signatures; Counterparts. This Petition may be conducted by electronic means and executed in several counterparts, including by electronic signature, all or any of which may be treated for all purposes as an original and shall constitute and be one and the

same instrument.

Section 6. Successors and Assigns. This Petition shall be binding upon the Petitioner and its successors and assigns.

IN WITNESS WHEREOF, the undersigned Petitioner has executed this Petition as on the date first hereinabove set forth.

PAYSON SOUTH MEADOW PARTNERS, LLC, a Utah
limited liability company

By Joseph A Spencer
Signature of Joseph A Spencer
12/21/2015
Its: Manager

EXHIBIT A

DESCRIPTION OF PROPERTY

PARCEL 1

Tax Parcel: 30-060-0131

PARCEL 2:

Tax Parcel: 30-060-0046

PARCEL 3:

Tax Parcel: 30-060-0126

PARCEL 4:

Tax Parcel: 30-060-0129

PARCEL 5:

Tax Parcel: 30-060-0130

PARCEL 6:

Tax Parcel: 30-060-0127

PARCEL 7:

Tax Parcel: 30-060-0132

PARCEL 8:

Tax Parcel: 30-060-0125

PARCEL 9:

Tax Parcel: 30-060-0104

Document History

SignNow E-Signature Audit Log

All dates expressed in MM/DD/YYYY (US)

Document name: Petition to Join PID - Red Bridge PID No 2 (Payson Business Center)
Document created: 12/23/2022 15:36:41
Document pages: 5
Document ID: 1b95e0ccbdb34ed6a4acd97d89664c68e9d5f9eb
Document Sent: 12/23/2022 15:38:05 UTC
Document Status: Signed
 12/23/2022 15:38:56UTC

Sender: josephspencer@gmail.com
Signers: josephspencer@gmail.com
CC:

Client	Event	By	Server Time	Client Time	IP Address
SignNow Web Application	Uploaded the Document	josephspencer@gmail.com	12/23/2022 15:36:41 pm UTC	12/23/2022 15:36:33 pm UTC	73.127.23.18
SignNow Web Application	Viewed the Document	josephspencer@gmail.com	12/23/2022 15:37:05 pm UTC	12/23/2022 15:37:05 pm UTC	73.127.23.18
SignNow Web Application	Document Saved	josephspencer@gmail.com	12/23/2022 15:37:44 pm UTC	12/23/2022 15:37:42 pm UTC	73.127.23.18
SignNow Web Application	Invite Sent to josephspencer@gmail.com	josephspencer@gmail.com	12/23/2022 15:38:05 pm UTC	12/23/2022 15:38:05 pm UTC	73.127.23.18
SignNow Web Application	Viewed the Document	josephspencer@gmail.com	12/23/2022 15:38:14 pm UTC	12/23/2022 15:38:11 pm UTC	73.127.23.18
SignNow Web Application	Signed the Document, Signature ID: 7252231e03c04b72b3a9	josephspencer@gmail.com	12/23/2022 15:38:56 pm UTC	12/23/2022 15:38:56 pm UTC	73.127.23.18
SignNow Web Application	Added a Text	josephspencer@gmail.com	12/23/2022 15:38:56 pm UTC	12/23/2022 15:38:56 pm UTC	73.127.23.18
SignNow Web Application	Document Saved	josephspencer@gmail.com	12/23/2022 15:38:56 pm UTC	12/23/2022 15:38:56 pm UTC	73.127.23.18

December 22, 2022

The Board of Trustees (the "*Board*") of Red Bridge Public Infrastructure District No. 2, Utah (the "*District*"), met in public session on December 22, 2022, virtually via video at 10:00 a.m., Utah time, due, legal and timely notice of the meeting having been given as required by law and the rules of the Board.

The meeting was called to order by the Chair. On roll call, the following members, constituting a quorum, were present:

Trustee	Joe Spencer
Trustee	Sheila Michaelis
Trustee	Blaine Turner
ABSENT:	None

The District Clerk presented to the Board an affidavit evidencing the giving of not less than twenty-four (24) hours' public notice of the agenda, date, time and place of the December 22, 2022 regular meeting of the Board in compliance with the requirements of Section 52-4-202(1), Utah Code Annotated 1953, as amended, by posting written notice of the meeting at the Utah Public Notice Website. The affidavit was ordered recorded in the minutes of the meeting and is as follows:

STATE OF UTAH)
)
COUNTY OF UTAH)

I, the undersigned, the duly qualified and acting District Clerk of the Red Bridge Public Infrastructure District No. 2, Utah (the "*District*"), do hereby certify that, according to the records of the Board of Trustees of the District (the "*Board*") in my official possession, and upon my own knowledge and belief, in accordance with the requirements of Section 52-4-202(1), Utah Code Annotated 1953, as amended, I gave not less than twenty-four (24) hours' public notice of the agenda, date, time and place of the December 22, 2022 regular public meeting held by the Board, by causing a Notice of Public Meeting to be posted at the Utah Public Notice Website at least twenty-four (24) hours before the convening of the meeting.

IN WITNESS WHEREOF, I have hereunder subscribed my official signature this December 22, 2022.

Sheila Michaelis

Sheila Michaelis, District Clerk
12/23/2022 16:34:12 UTC

After the conduct of other business not pertinent to the following, the following resolution was introduced in written form for consideration by the Board. After due consideration of the resolution by the Board, Sheila Michaelis moved for its adoption, and Blaine Turner seconded the motion. On being put to a vote, the motion was carried by the following vote:

AYE: Joe Spencer
Sheila Michaelis
Blaine Turner

NAY: None

ABSENT: None

The resolution is as follows:

RESOLUTION – ANNEXATION OF PROPERTIES INTO DISTRICT

A RESOLUTION AUTHORIZING THE ANNEXATION OF PROPERTIES INTO THE DISTRICT

WHEREAS, the City of Payson, Utah (the “*City*”) created Red Bridge Public Infrastructure District No. 2 (the “*District*”) pursuant to the Governing Document for the District (the “*Governing Document*”);

WHEREAS, the Governing Document included the consent of the City to annex certain properties into the boundaries of the District set forth in the Governing Document (the “*Annexation Area*”);

WHEREAS, the District has received the petitions attached hereto as *Exhibit A* (the “*Petitions*”) from property owners (“*Petitioners*”) desiring to be annexed into the boundaries of the District (the “*Petitioning Properties*”) in order to assist in the financing of public infrastructure relating to the development of property in the District (the “*Improvements*”);

WHEREAS, all of the Petitioning Properties are located in the Annexation Area; and

WHEREAS, the Board of Trustees of the District (the “*Board*”) desires to annex the Petitioning Properties into the boundaries of the District;

NOW, THEREFORE, Be it Resolved by the Board of Trustees of Red Bridge Public Infrastructure District No. 2, as follows:

Section 1. The Petitioning Properties set forth in *Exhibit A* hereto are hereby authorized to be annexed into the boundaries of the District and, upon annexation, shall be subject to any property tax levied by the District.

Section 2. The officers, employees and agents of the District shall take all action necessary or reasonably required to carry out, give effect to, and consummate the transactions contemplated hereby and shall take all action necessary in conformity with Utah law.

Section 3. The Board hereby ratifies, confirms and approves all actions heretofore taken by the officers and agents of the District relating to the transactions contemplated hereby.

Section 4. It is hereby declared that all parts of this resolution are severable, and if any section, paragraph, clause or provision of this resolution shall, for any reason, be held to be invalid or unenforceable, the invalidity or unenforceability of any such section, paragraph, clause or provision shall not affect the remaining sections, paragraphs, clauses or provisions of this resolution.

Section 5. All resolutions or parts thereof in conflict herewith are, to the extent of such conflict, hereby repealed and this resolution shall be in full force and effect immediately upon its adoption.

APPROVED AND ADOPTED this December 22, 2022.

By Joseph A Spencer
SignNow e-signature ID: 90454a9809...
12/22/22 15:57:45 UTC

COUNTERSIGN AND ATTEST:

By Sheila Michaelis
SignNow e-signature ID: 9639225c5a...
12/22/22 15:57:45 UTC

(Other business not pertinent to the above appears in the minutes of the meeting.)

Pursuant to motion duly made and carried, the meeting was adjourned.

RED BRIDGE PUBLIC INFRASTRUCTURE DISTRICT
NO. 2, UTAH

By Joseph A Spencer

Digitally signed by Joseph A Spencer
DN: cn=Joseph A Spencer, o=Red Bridge Public Infrastructure District, ou=District Clerk, email=jspencer@redbridgepi.com, c=US

ATTEST:

By Sheila Michaelis

Digitally signed by Sheila Michaelis
DN: cn=Sheila Michaelis, o=Red Bridge Public Infrastructure District, ou=District Clerk, email=smichaelis@redbridgepi.com, c=US

STATE OF UTAH)
)
COUNTY OF UTAH)

I, the duly chosen, qualified and acting District Clerk of Red Bridge Public Infrastructure District No. 2, Utah (the "District"), do hereby certify that the foregoing is a full, true and correct copy of the extracts of minutes of a regular meeting of the Board on December 22, 2022, including a resolution adopted at said meeting, as recorded in the regular official book of minutes of the proceedings of the Board kept in my office, that all members were given due, legal and timely notice of said meeting, that the meeting therein shown was in all respects called, held and conducted in accordance with law and in full conformity therewith, and that the persons therein named were present at the meeting, as therein shown.

IN WITNESS WHEREOF, I have hereunto set my hand this December 22, 2022.

Sheila Michaelis

Sheila Michaelis
District Clerk
12/23/2022 16:34:12 UTC

EXHIBIT A

COPIES OF PETITIONS

FINAL LOCAL ENTITY PLAT

RED BRIDGE PUBLIC INFRASTRUCTURE DISTRICT NO. 2 PLAT "C"

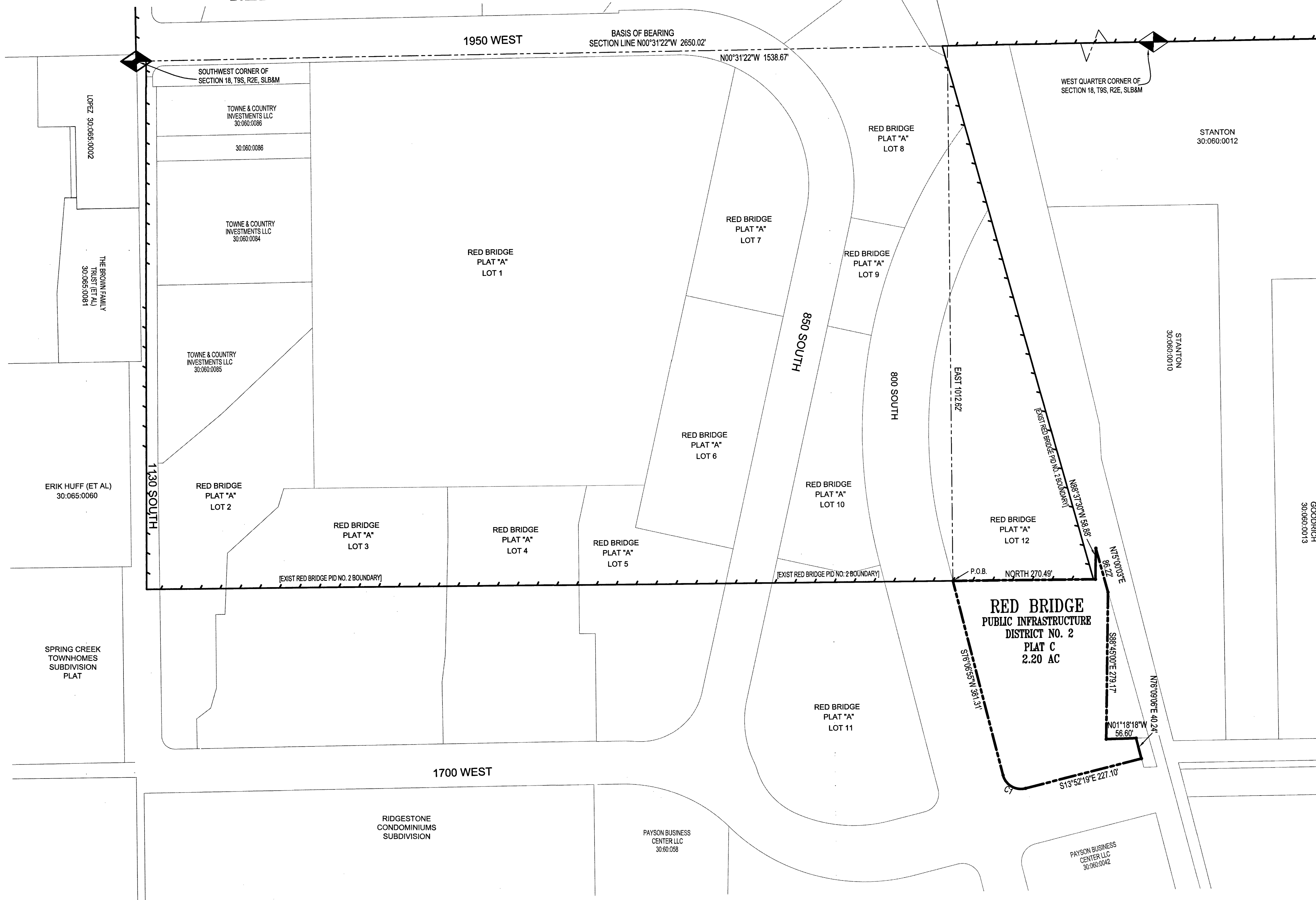

SURVEYOR'S CERTIFICATE
 I, AARON D. THOMAS DO HEREBY CERTIFY THAT I AM A PROFESSIONAL LAND SURVEYOR, AND THAT I HOLD CERTIFICATE NUMBER 6418780 IN ACCORDANCE WITH TITLE 58, CHAPTER 22 OF THE PROFESSIONAL ENGINEERS AND LAND SURVEYORS LICENSING ACT, UTAH CODE ANNOTATED, 1993 AMENDED. I FURTHER CERTIFY THAT THIS IS A TRUE AND ACCURATE MAP OF THE LOCAL ENTITY PLAT SHOWN AND DESCRIBED HEREON.

BOUNDARY DESCRIPTION
 BEGINNING AT A POINT WHICH IS NORTH 00°31'22" WEST 1538.67 ALONG THE SECTION LINE AND EAST 1012.62 FEET FROM THE SOUTHWEST CORNER OF SECTION 18, TOWNSHIP 9 SOUTH, RANGE 2 EAST, SALT LAKE BASE AND MERIDIAN;
 THENCE ALONG THE EXISTING RED BRIDGE PID NO.1 BOUNDARY THE FOLLOWING COURSE: NORTH 270.49 FEET; THENCE NORTH 88°37'30" WEST 58.88 FEET; THENCE NORTH 75°00'03" EAST 86.22 FEET; THENCE SOUTH 88°45'00" EAST 279.17 FEET; THENCE NORTH 01°18'18" WEST 56.80 FEET; THENCE NORTH 76°09'06" EAST 40.24 FEET TO A POINT ALONG THE WESTERLY RIGHT-OF-WAY LINE OF 1700 WEST; THENCE ALONG SAID RIGHT-OF-WAY THE FOLLOWING COURSE: SOUTH 13°52'19" EAST 227.10 FEET TO A POINT ALONG THE NORTHERLY RIGHT-OF-WAY LINE OF 800 SOUTH; THENCE ALONG SAID RIGHT-OF-WAY THE FOLLOWING TWO (2) COURSES: 1) ALONG THE ARC OF A 35.00 FOOT RADIUS CURVE TO THE RIGHT A DISTANCE OF 54.97 FEET (CURVE HAVING A CENTRAL ANGLE 89°59'14" AND LONG CHORD S31°07'18" W 49.49 FEET), AND 2) SOUTH 76°06'55" WEST 381.31 FEET TO THE POINT OF BEGINNING.
 CONTAINING: 95,948 SF OR 2.20 ACRES.
 BASIS OF BEARING: NORTH 00°31'22" WEST ALONG THE SECTION LINE 2650.02 FEET BETWEEN THE SOUTHWEST AND WEST QUARTER CORNER OF SAID SECTION.

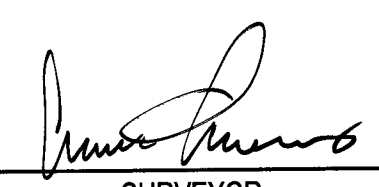
 SURVEYOR
 DEC. 20, 2022
 DATE

ACCEPTANCE BY LEGISLATIVE BODY
 APPROVED THIS 23rd DAY OF DECEMBER, 2022 AS A FINAL ENTITY PLAT FOR THE
 RED BRIDGE PUBLIC INFRASTRUCTURE DISTRICT NO. 2 PLAT C

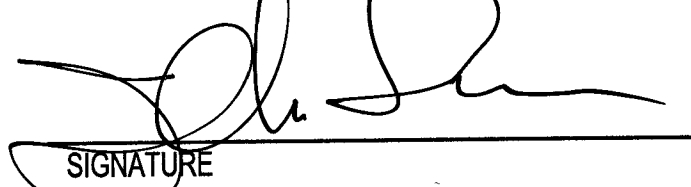
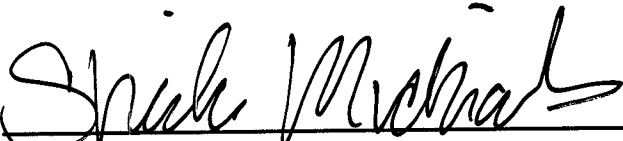
 SIGNATURE
 JOSEPH A SPENCER
 PRINTED NAME
 Chairman, Red Bridge Public Infrastructure Dist #2 of No.2
 TITLE
 ATTEST: 
 RECORDER
 Sheila Michaelis

FINAL LOCAL ENTITY PLAT

RED BRIDGE PUBLIC INFRASTRUCTURE DISTRICT NO. 2 PLAT "C"

PAYSON CITY, UTAH COUNTY, UTAH

LOCATED IN SOUTHWEST QUARTER OF SECTION 18, TOWNSHIP 9 SOUTH, RANGE 2 EAST,
SALT LAKE BASE AND MERIDIAN.
PAYSON CITY,
UTAH COUNTY, UTAH

SCALE: 1"=100'

THIS PLAT HAS BEEN REVIEWED BY THE COUNTY SURVEYOR AND IS HEREBY CERTIFIED AS A FINAL LOCAL ENTITY PLAT, PURSUANT TO UTAH CODE ANNOTATED 17-23-20 AS AMENDED.

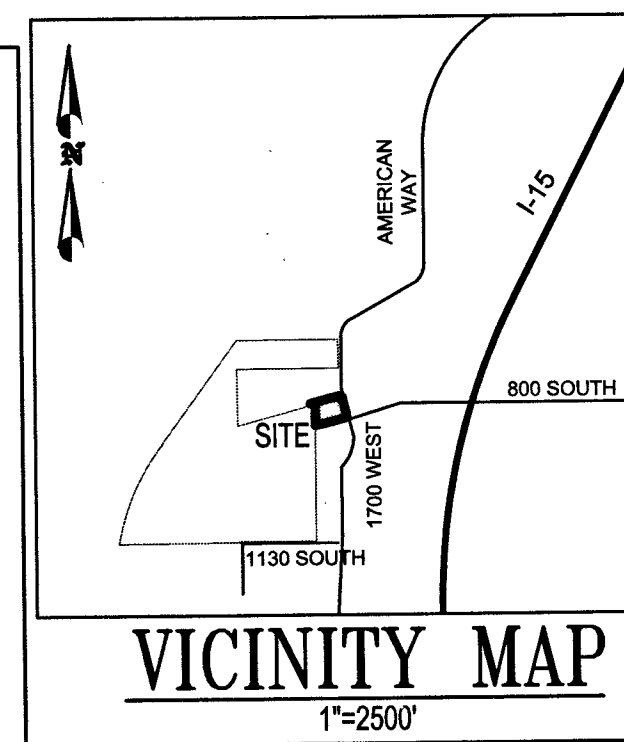

CURVE TABLE					
CURVE	RADIUS	LENGTH	DELTA	CHORD	BEARING
C1	35.00	54.97	89°52'14"	49.49	S31°07'18" W

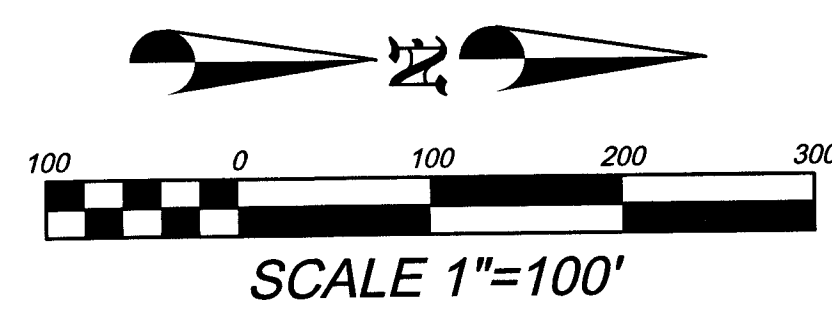

SURVEYOR
AZTEC ENGINEERING
 732 North 780 West
 American Fork, UT 84003
 (801) 224-7308

ENGINEER

CIVIL ENGINEERING
 11038 N Highland Blvd Suite 400
 Highland UT, 84003
 office (801) 492-1277
 cell (801) 616-1677

12/20/2022

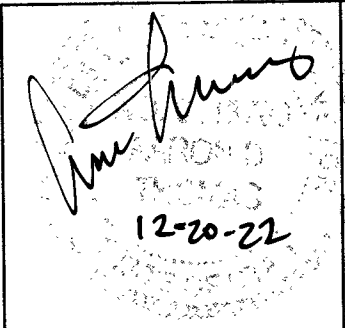
SURVEYOR'S SEAL  12-20-22	CITY RECORDER SEAL	COUNTY RECORDER SEAL
--	--------------------	----------------------

UTAH COUNTY SURVEYOR

 DATE

FINAL LOCAL ENTITY PLAT

RED BRIDGE PUBLIC INFRASTRUCTURE DISTRICT NO. 2 PLAT "D"

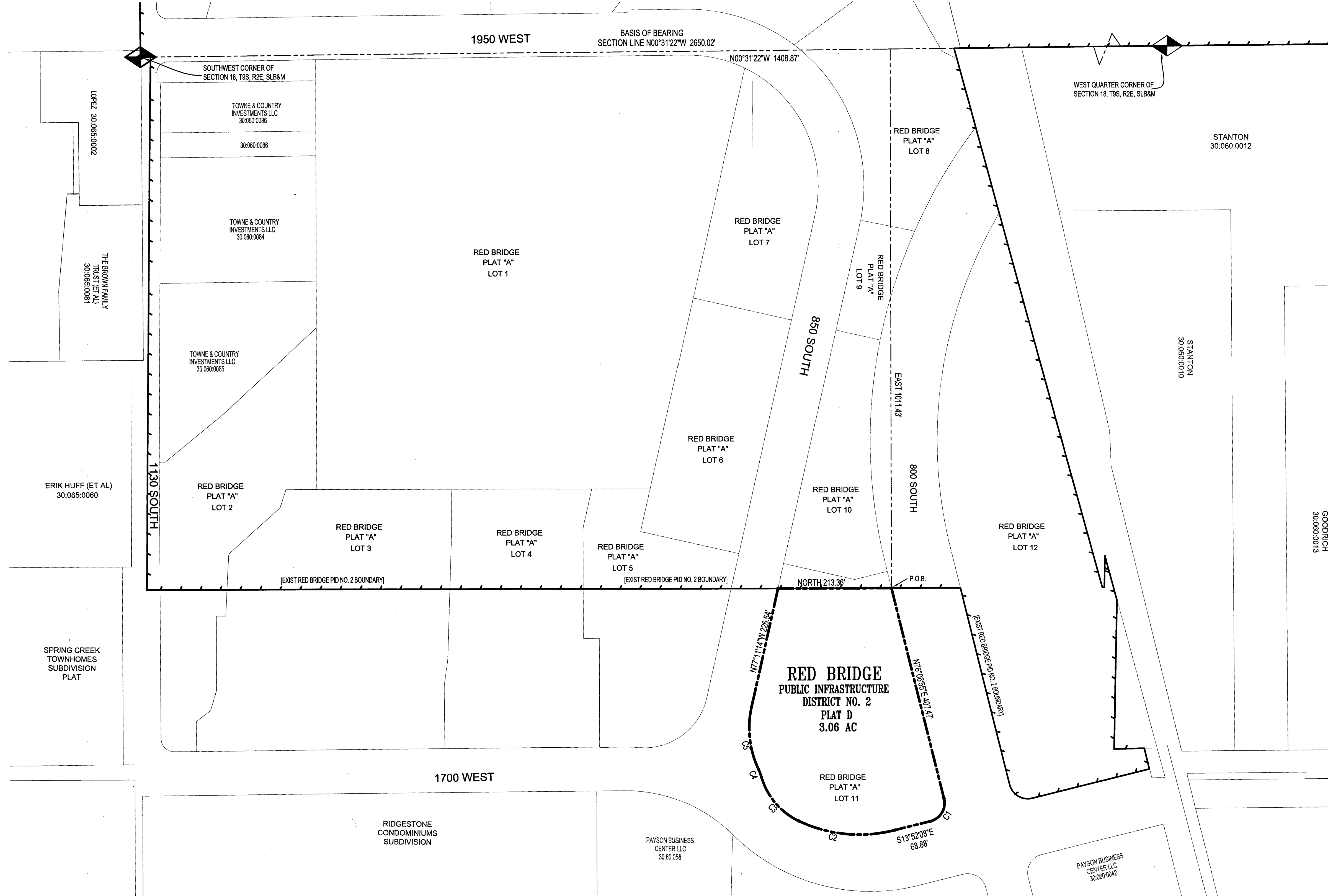

SURVEYOR'S CERTIFICATE
 I, AARON D. THOMAS, DO HEREBY CERTIFY THAT I AM A PROFESSIONAL LAND SURVEYOR, AND THAT I HOLD CERTIFICATE NUMBER 6418780 IN ACCORDANCE WITH TITLE 58, CHAPTER 22 OF THE PROFESSIONAL ENGINEERS AND LAND SURVEYORS LICENSING ACT, UTAH CODE ANNOTATED, 1953 AMENDED. I FURTHER CERTIFY THAT THIS IS A TRUE AND ACCURATE MAP OF THE LOCAL ENTITY PLAT SHOWN AND DESCRIBED HEREON.

BOUNDARY DESCRIPTION

BEGINNING AT A POINT WHICH IS NORTH 00°31'22" WEST 1408.87 ALONG THE SECTION LINE AND EAST 1011.43 FEET FROM THE SOUTHWEST CORNER OF SECTION 18, TOWNSHIP 9 SOUTH, RANGE 2 EAST, SALT LAKE BASE AND MERIDIAN;

THENCE ALONG THE SOUTH RIGHT-OF-WAY LINE OF 800 SOUTH THE FOLLOWING TWO (2) COURSES: 1) NORTH 76°06'55" EAST 407.47 FEET, AND 2) ALONG THE ARC OF A 35.00 FOOT RADIUS CURVE TO THE RIGHT A DISTANCE OF 54.99 FEET (CURVE HAVING A CENTRAL ANGLE 90°00'57" AND LONG CHORD S58°52'36"E 49.50 FEET) TO A POINT ALONG THE WEST RIGHT-OF-WAY LINE OF 1700 WEST. THENCE ALONG 1700 WEST RIGHT-OF-WAY THE FOLLOWING FOUR (4) COURSES: 1) SOUTH 13°52'08" EAST 88.88 FEET, 2) ALONG THE ARC OF A 286.00 FOOT RADIUS CURVE TO THE RIGHT A DISTANCE OF 186.25 FEET (CURVE HAVING A CENTRAL ANGLE 40°07'04" AND LONG CHORD S05°42'39"W 182.47 FEET), 3) ALONG THE ARC OF A 133.00 FOOT RADIUS CURVE TO THE RIGHT A DISTANCE OF 110.79 FEET (CURVE HAVING A CENTRAL ANGLE 47°43'37" AND LONG CHORD S49°54'37"W 107.61 FEET), AND 4) ALONG THE ARC OF A 106.50 FOOT RADIUS CURVE TO THE LEFT A DISTANCE OF 16.01 FEET (CURVE HAVING A CENTRAL ANGLE 08°36'45" AND LONG CHORD S89°28'03"W 15.99 FEET) TO A POINT ALONG THE NORTH RIGHT-OF-WAY LINE OF 850 SOUTH; THENCE ALONG 850 SOUTH RIGHT-OF-WAY THE FOLLOWING TWO (2) COURSES: 1) ALONG THE ARC OF A 184.00 FOOT RADIUS CURVE TO THE RIGHT A DISTANCE OF 120.92 FEET (CURVE HAVING A CENTRAL ANGLE 37°39'06" AND LONG CHORD S83°59'13"W 118.75 FEET), AND 2) NORTH 77°11'14" WEST 228.54 FEET TO ALONG THE EXISTING RED BRIDGE PID NO. 1 BOUNDARY; THENCE ALONG THE PID BOUNDARY THE FOLLOWING COURSE: NORTH 213.36 FEET TO THE POINT OF BEGINNING.

CONTAINING: 133,217 SF OR 3.06 ACRES.

BASIS OF BEARING: NORTH 00°31'22" WEST ALONG THE SECTION LINE 2650.02 FEET BETWEEN THE SOUTHWEST AND WEST QUARTER CORNER OF SAID SECTION.

SURVEYOR
 DEC. 20, 2022
 DATE

ACCEPTANCE BY LEGISLATIVE BODY

APPROVED THIS 23rd DAY OF DECEMBER, 2022 AS A FINAL ENTITY PLAT FOR THE
 RED BRIDGE PUBLIC INFRASTRUCTURE DISTRICT NO. 2 PLAT D

SIGNATURE
JOSEPH A. SPENCER
 PRINTED NAME
 Chairman, Red Bridge Public Infrastructure District No. 2
 TITLE

ATTEST:
 RECORDER
 Sheila Michaelis

FINAL LOCAL ENTITY PLAT

RED BRIDGE

PUBLIC INFRASTRUCTURE DISTRICT NO. 2

PLAT "D"

PAYSON CITY, UTAH COUNTY, UTAH

LOCATED IN SOUTHWEST QUARTER OF SECTION 18, TOWNSHIP 9 SOUTH, RANGE 2 EAST, SALT LAKE BASE AND MERIDIAN.
 PAYSON CITY, UTAH COUNTY, UTAH

SCALE: 1"=100'

THIS PLAT HAS BEEN REVIEWED BY THE COUNTY SURVEYOR AND IS HEREBY CERTIFIED AS A FINAL LOCAL ENTITY PLAT, PURSUANT TO UTAH CODE ANNOTATED 17-23-20 AS AMENDED.

UTAH COUNTY SURVEYOR _____
 DATE _____

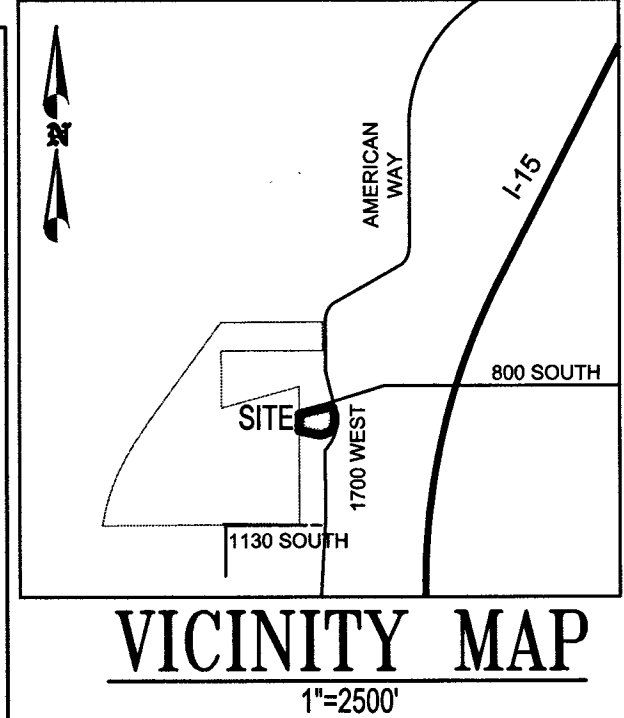

CURVE TABLE				
CURVE	RADIUS	LENGTH	DELTA	BEARING
C1	35.00	54.99	90°00'57"	S58°52'36"E
C2	286.00	186.25	40°07'04"	S05°42'39"W
C3	133.00	110.79	47°43'37"	S49°54'37"W
C4	106.50	16.01	08°36'45"	S89°28'03"W
C5	184.00	120.92	37°39'06"	S83°59'13"W

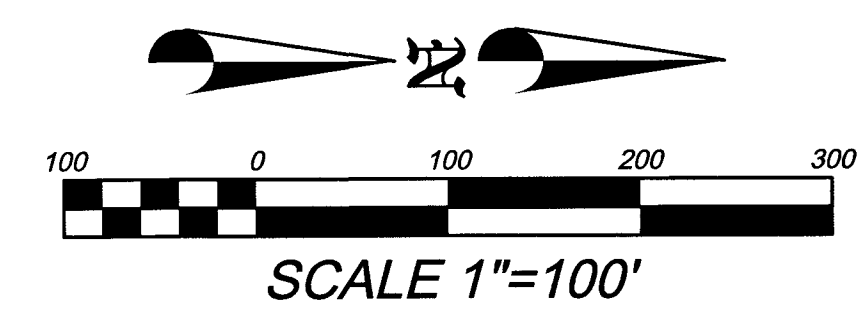

SURVEYOR
AZTEC ENGINEERING
 732 North 780 West,
 American Fork, UT 84003
 (801) 224-7308

ENGINEER

BERG
 CIVIL ENGINEERING
 11038 N Highland Blvd Suite 400
 Highland, UT 84003
 office (801) 482-1277
 cell (801) 616-1677

12/20/2022

SURVEYOR'S SEAL CITY RECORDER SEAL COUNTY RECORDER SEAL

12-20-22

FINAL LOCAL ENTITY PLAT

RED BRIDGE PUBLIC INFRASTRUCTURE DISTRICT NO. 2 PLAT "E"

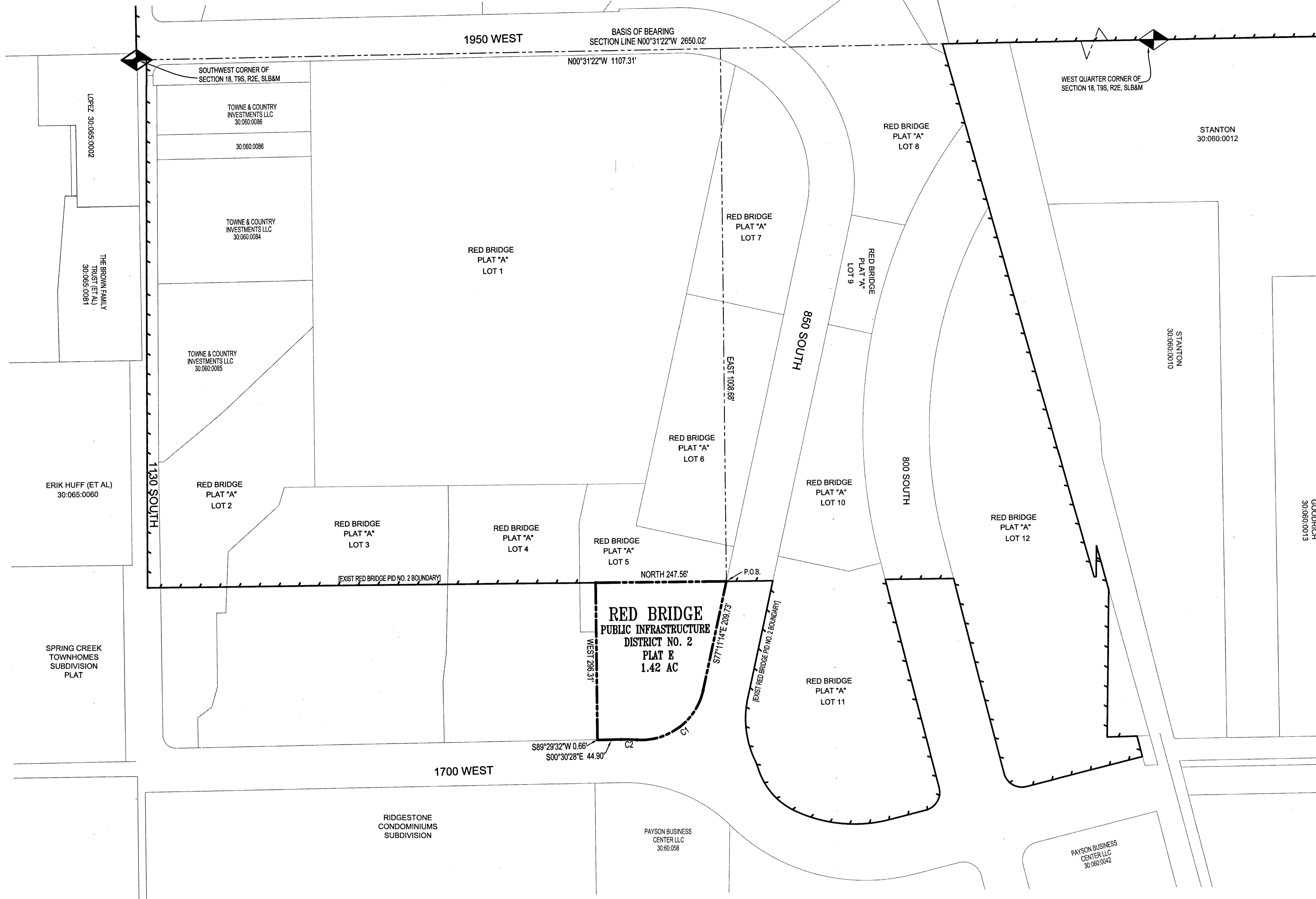

SURVEYOR'S CERTIFICATE

I, AARON D. THOMAS DO HEREBY CERTIFY THAT I AM A PROFESSIONAL LAND SURVEYOR, AND THAT I HOLD CERTIFICATE NUMBER 6418780 IN ACCORDANCE WITH TITLE 58, CHAPTER 22 OF THE PROFESSIONAL ENGINEERS AND LAND SURVEYORS LICENSING ACT, UTAH CODE ANNOTATED, 1953 AMENDED. I FURTHER CERTIFY THAT THIS IS A TRUE AND ACCURATE MAP OF THE LOCAL ENTITY PLAT SHOWN AND DESCRIBED HEREON.

BOUNDARY DESCRIPTION

BEGINNING AT A POINT WHICH IS NORTH 00°31'22" WEST 1107.31 ALONG THE SECTION LINE AND EAST 1008.68 FEET FROM THE SOUTHWEST CORNER OF SECTION 18, TOWNSHIP 9 SOUTH, RANGE 2 EAST, SALT LAKE BASE AND MERIDIAN;

THENCE ALONG THE SOUTH RIGHT-OF-WAY LINE OF 850 SOUTH THE FOLLOWING TWO (2) COURSES: 1) SOUTH 77°11'14" EAST 209.73 FEET, AND 2) ALONG THE ARC OF A 120.00 FOOT RADIUS CURVE TO THE RIGHT A DISTANCE OF 170.53 FEET (CURVE HAVING A CENTRAL ANGLE 81°25'22" AND LONG CHORD S36°28'33"E 156.54 FEET) TO A POINT ALONG THE WEST RIGHT-OF-WAY LINE OF 1700 WEST; THENCE ALONG 1700 WEST RIGHT-OF-WAY THE FOLLOWING THREE (3) COURSES: 1) ALONG THE ARC OF A 366.00 FOOT RADIUS CURVE TO THE LEFT A DISTANCE OF 30.30 FEET (CURVE HAVING A CENTRAL ANGLE 04°44'36" AND LONG CHORD S01°51'51"W 30.29 FEET), 2) SOUTH 00°30'28" EAST 44.90 FEET, AND 3) SOUTH 89°29'32" WEST 0.66 FEET; THENCE WEST 296.31 FEET TO A POINT ALONG THE EXISTING RED BRIDGE PID NO.1 BOUNDARY; THENCE ALONG THE PID BOUNDARY THE FOLLOWING COURSE: NORTH 247.56 FEET TO THE POINT OF BEGINNING.

CONTAINING: 61,781 SF OR 1.42 ACRES.

BASIS OF BEARING: NORTH 00°31'22" WEST ALONG THE SECTION LINE 2650.02 FEET BETWEEN THE SOUTHWEST AND WEST QUARTER CORNER OF SAID SECTION.

Aaron D. Thomas
SURVEYOR

DEC. 20, 2022
DATE

ACCEPTANCE BY LEGISLATIVE BODY

APPROVED THIS 23RD DAY OF DECEMBER, 2022 AS A FINAL ENTITY PLAT FOR THE
RED BRIDGE PUBLIC INFRASTRUCTURE DISTRICT NO. 2 PLAT E

Joseph A. Spencer
SIGNATURE

JOSEPH A. SPENCER
PRINTED NAME

Chairman, Red Bridge Public Infrastructure District No. 2
TITLE

ATTEST: *Shaile Michaelis*
RECORDER

FINAL LOCAL ENTITY PLAT

RED BRIDGE

PUBLIC INFRASTRUCTURE DISTRICT NO. 2

PLAT "E"

PAYSON CITY, UTAH COUNTY, UTAH

LOCATED IN SOUTHWEST QUARTER OF SECTION 18, TOWNSHIP 9 SOUTH, RANGE 2 EAST, SALT LAKE BASE AND MERIDIAN.
PAYSON CITY, UTAH COUNTY, UTAH

SCALE: 1"=100'

THIS PLAT HAS BEEN REVIEWED BY THE COUNTY SURVEYOR AND IS HEREBY CERTIFIED AS A FINAL LOCAL ENTITY PLAT, PURSUANT TO UTAH CODE ANNOTATED 17-23-20 AS AMENDED.

UTAH COUNTY SURVEYOR _____
DATE _____

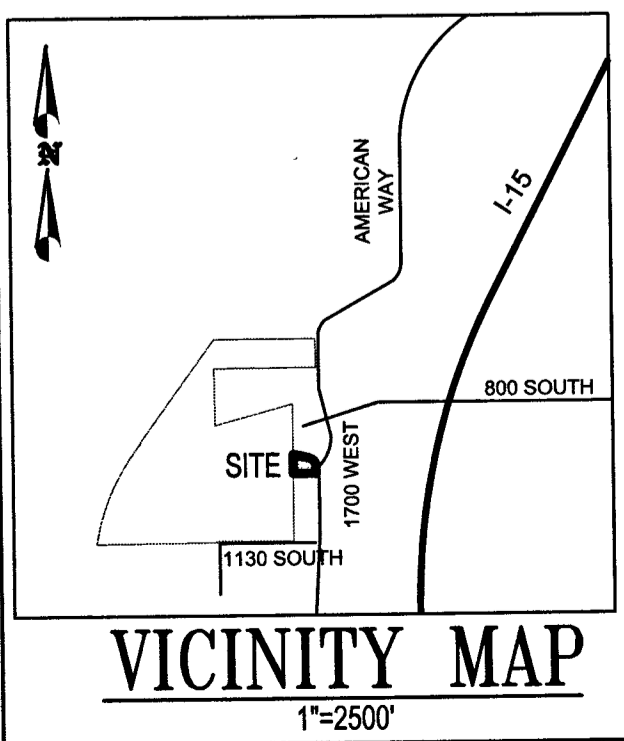

CURVE TABLE					
CURVE	RADIUS	LENGTH	DELTA	CHORD	BEARING
C1	120.00	170.53	81°25'22"	156.54	S36°28'33"E
C2	366.00	30.30	04°44'36"	30.29	S01°51'51"W

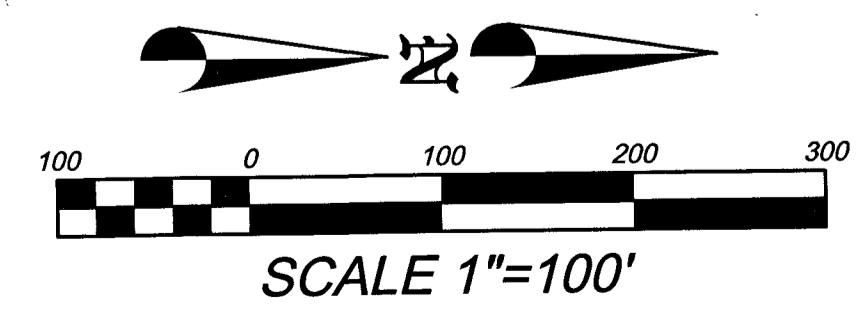

SURVEYOR
AZTEC ENGINEERING
732 North 780 West,
American Fork, UT 84003
(801) 224-7308

ENGINEER
Berg
CIVIL ENGINEERING
11036 N Highland Blvd Suite 400
Highland UT, 84003
office (801) 492-1277
cell (801) 616-1677

12/20/2022

SURVEYOR'S SEAL CITY RECORDER SEAL COUNTY RECORDER SEAL

Aaron D. Thomas
12-20-22